

# BAS-705

## Automatic Belt Loop Sewer



### Specifications

Machine head	Lock stitch pattern tacker
Sewing speed	2,100 rpm
Stitch length	0.1-10.0 mm
Sewing area X-Y	22 × 3 mm
Number of stitches	29, 36, 43
Height of presser foot	19 mm
Needle type	DP × 17NY #19, #21
Shuttle hook	Double
Needle gauge	40-70 mm
Loop cutting	Flat-end or V-shaped cut selection
Loop width	Flat cut : 9– 20 mm, V-cut : 9– 16 mm
Machine time	1.4sec. / loop (29 stitches)
Cycle time	14sec. (29 stitches, 5 loops, including handling)
Power source	3-phase 220 V, 380 V, 400 V, 415 V 600 VA
Air pressure	0.5 – 0.55 Mpa 90 l / min.
Table height	1,000-1,150 mm
Machine dimensions	1100 (W) × 837 (L) × 1,320 - 1,530 (H) mm
Weight	205 kg (220 V), 230 kg (380 V, 400 V, 415 V)

# BAS-705-0□0

Device			
	Belt slack equipment	Clipping disposal funnel assembly	Upper thread breakage detector
0	—	—	—
1	○	—	—
2	—	○	—
3	—	—	○
4	○	○	—
5	○	—	○
6	—	○	○
7	○	○	○

## Operation panel setting

Loop length	50 - 120 mm
Bobbin counter	0 - 999
Production counter	Max. 9999
Sewing speed	1,900 - 2,100 rpm ( in steps of 100 rpm)
Sewing pattern	Select from 3 sewing patterns (3 settings <enlargement and reduction> can be applied to each of the patterns)
Enlarging and reducing patterns	45 - 120% in both X and Y directions (with area check)

# GAUGE PARTS LIST

## Needle hole plate

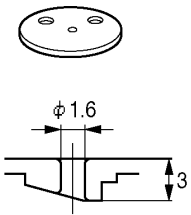
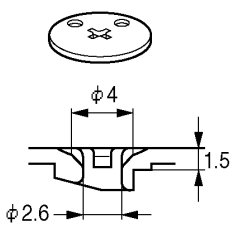
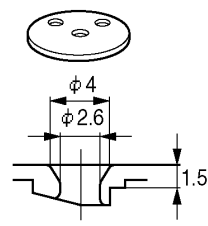
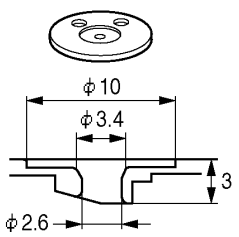
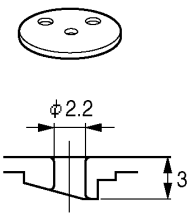
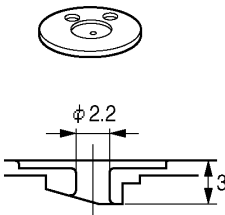
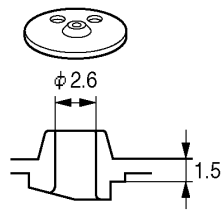
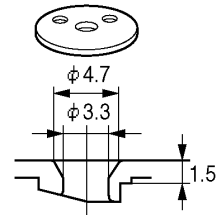
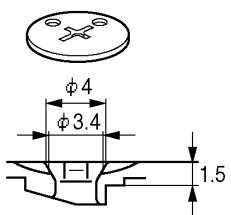
<p>Needle hole plate, A S10211-001</p> 	<p>Needle hole plate, D S29997-001</p> 	<p>Needle hole plate, E S10212-101</p> 	<p>Needle hole plate, ED S30925-001</p> 
<p>Needle hole plate, F S10213-001</p> 	<p>Needle hole plate, FD S30926-001</p> 	<p>Needle hole plate, H S30450-001</p> 	<p>Needle hole plate, L S25127-001</p> 
<p>Needle hole plate, EX S45188-001</p>			
			

## Presser foot

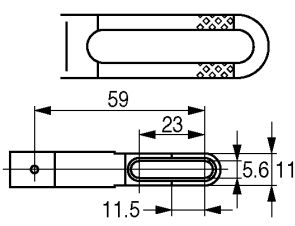
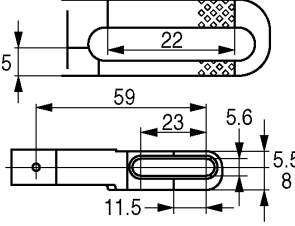
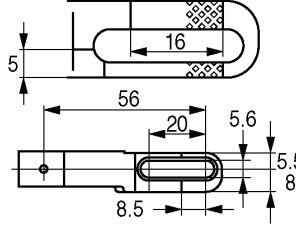
<p>Work clamp &lt;For bar tack length: Max. 23 mm&gt; S41796-101</p>	<p>Work clamp, F &lt;For bar tack length: Max. 22 mm&gt; S44762-001</p>	<p>&lt;For bar tack length: Max. 16 mm&gt; S44763-001</p>
		

Needle plate (Option parts)

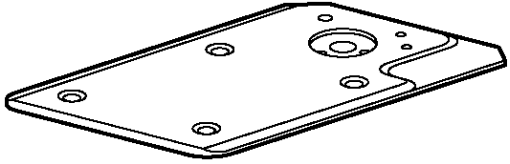
	Part name	Part code	Q'ty
	Needle plate, E BM	S46563-001	1

\*This part can deliver belt loops to a constant location because the fork does not make contact with the lap seams that are the thickest part of the material.

Feed plate

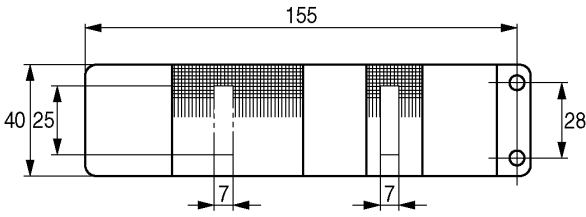
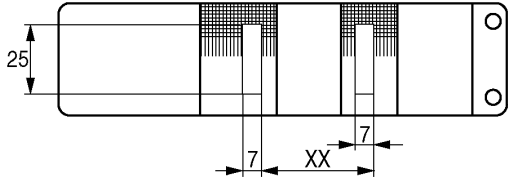
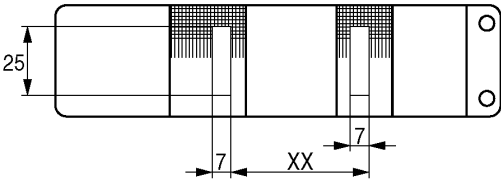
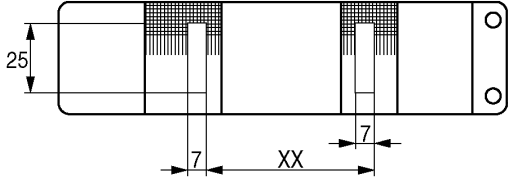
Feed plate (Blank) S41803-001	Feed plate, S S44961-0XX XX=40-53
	
Feed plate, M S44962-0XX XX=48-63	Feed plate, L S44963-0XX XX=58-70
	

\*Stitch interval = XX

Feeder mechanism

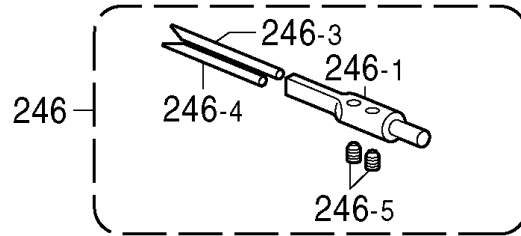

Ref. No.	Part name	Part code	Qty
For light materials loop			
246	Fork assy, A	S44957-001	2
246-1	Fork, A	S43959-001	2
246-3	Fork shaft, 2.0L	S41626-001	2
246-4	Fork shaft, 2.0S	S41627-001	2
246-5	Set screw, socket (FT) M4×4	012400-436	4
For medium materials loop			
246	Fork assy, B	S44958-001	2
246-1	Fork, B	S43960-001	2
246-3	Fork shaft, 2.0L	S41626-001	2
246-4	Fork shaft, 2.0S	S41627-001	2
246-5	Set screw, socket (FT) M4×4	012400-436	4
For heavy materials loop			
246	Fork assy, C	S44959-001	2
246-1	Fork, C	S43961-001	2
246-3	Fork shaft, 2.0L	S41626-001	2
246-4	Fork shaft, 2.0S	S41627-001	2
246-5	Set screw, socket (FT) M4×4	012400-436	4

Feeder mechanism

	Ref. No.	Part name	Part code	Q'ty
	343	Loop presser, 70B	S41594-001	1
	344	Loop presser, 70F	S41595-001	1

Feeder mechanism

For needle gauge 40 – 45 mm

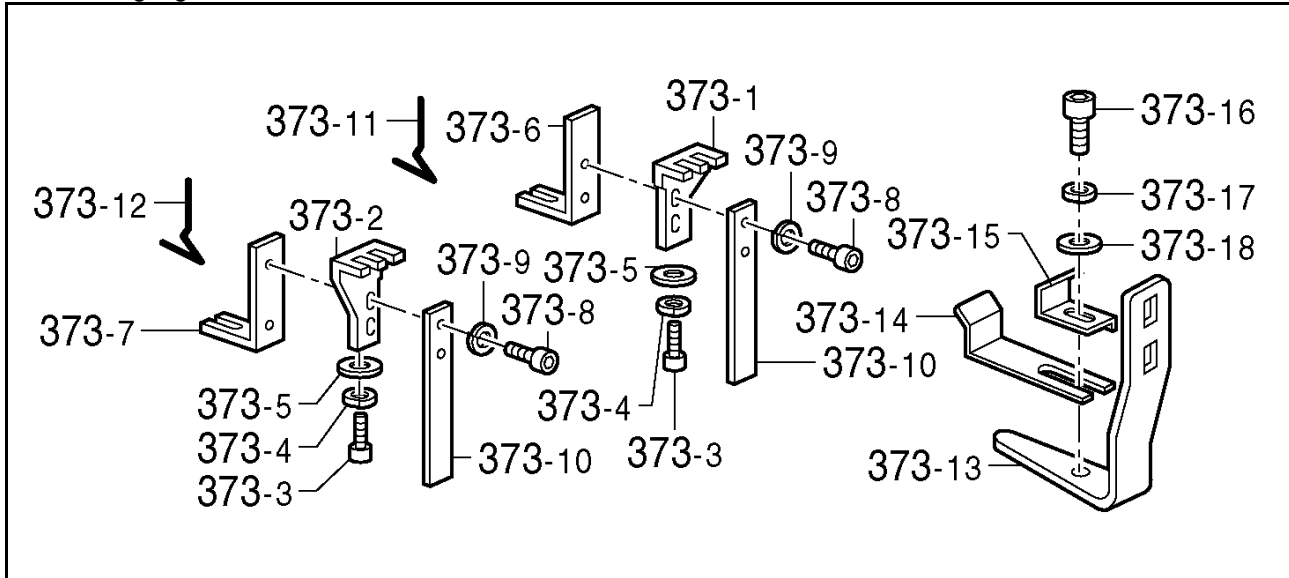

Ref. No.	Part name	Part code	Q'ty
373	Loop presser assy, 40	S44974-001	1
373-1	Loop presser setting pate, SB	S43969-001	1
373-2	Loop presser setting plate, SF	S43970-001	1
373-3	Bolt, socket M4×8	018400-836	4
373-4	Washer, spring 2-4	028040-246	4
373-5	Washer, plain M4	025040-236	4
373-6	Loop presser, 40B	S43967-001	1
373-7	Loop presser, 40F	S43968-001	1
373-8	Bolt, socket M4×8	018400-836	4
373-9	Washer, spring 2-4	028040-246	4
373-10	Loop wiper, S	S43963-001	2
373-11	Loop presser, UBS	S43965-001	1
373-12	Loop presser, UFS	S43966-001	1
373-13	Loop support, F	S41596-201	1
373-14	Loop guide, 1	S44964-000	1
373-15	Loop guide, 2	S44965-000	1
373-16	Bolt, socket M4×8	018400-836	1
373-17	Washer, spring 2-4	028040-246	1
373-18	Washer, plain M4	025040-236	1

Feeder mechanism  
Using the loop width 25.4mm for flat cut only

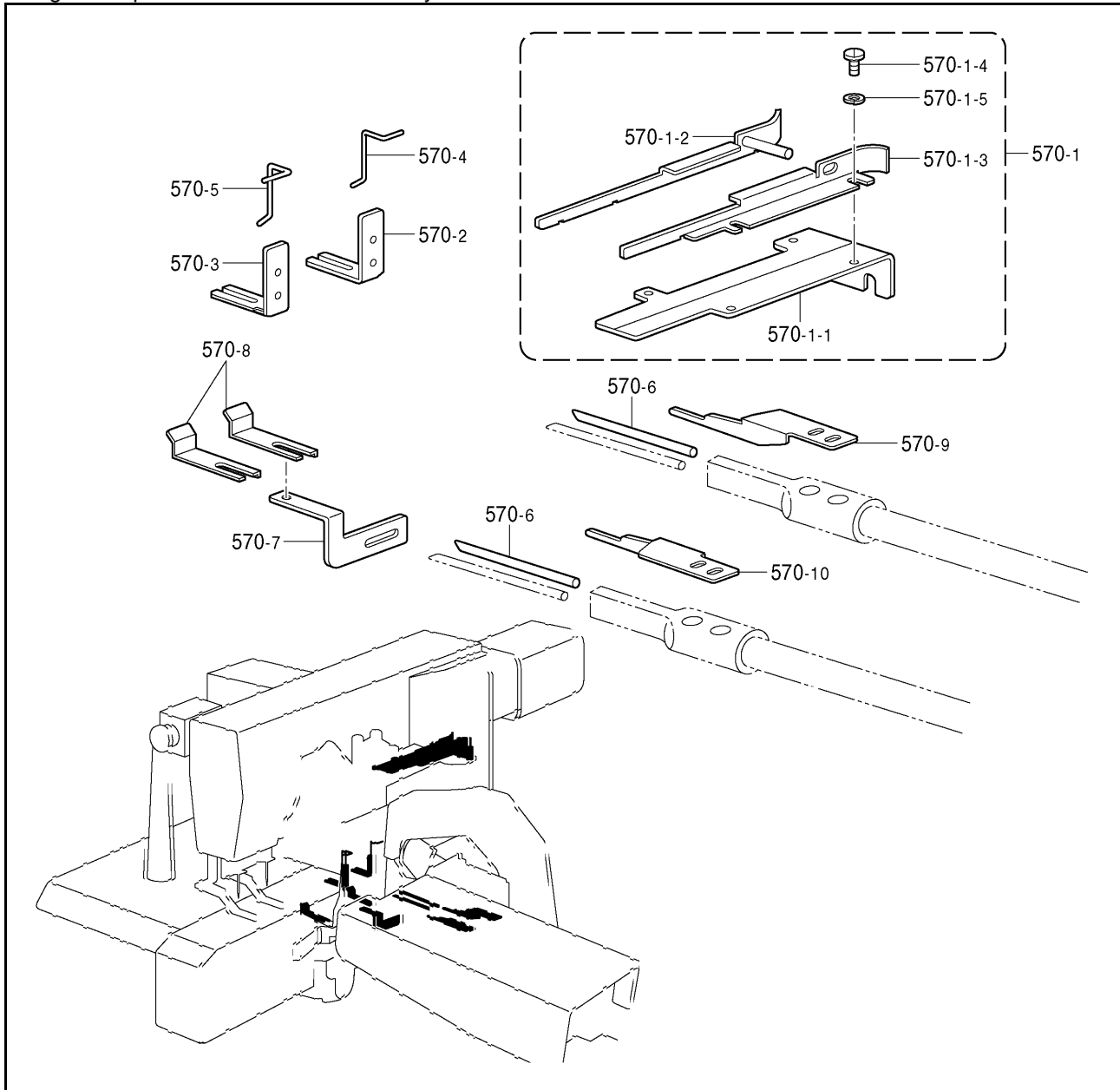

Ref. No.	Part name	Part code	Q'ty
570	Gauge set, 1	S47058-001	1
570-1	Channel assy, 25	S44983-001	1
570-1-1	Channel base, 25	S44984-001	1
570-1-2	Channel, back 25	S44985-001	1
570-1-3	Channel, front 25	S44986-001	1
570-1-4	Screw, bind M3×5	060300-516	4
570-1-5	Washer, bind 2 - 3	028030-246	4
570-2	Loop presser, BL	S44987-001	1
570-3	Loop presser, FL	S44988-001	1
570-4	Spring, wide narrow (BL)	S44989-001	1
570-5	Spring, wide narrow (FL)	S44990-001	1
570-6	Fork shaft, 2.0LL	S41919-001	2
570-7	Loop support, B2L	S47528-001	1
570-8	Loop guide, 1L	S47529-001	2
570-9	Loosen presser foot, BL	S47553-001	1
570-10	Loosen presser foot, FL	S47554-001	1

Power supply equipment mechanism

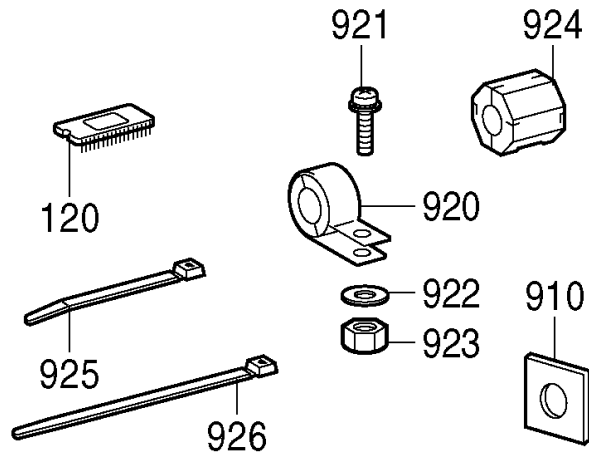

Ref. No.	Part name	Part code	Q'ty
120	PROM assy, I/O check 705	S46502-000	1
910	EM switch spacer, 3	S37057-001	1
920	EMI core, TR - 40 - 27	S40623-000	4
921	Screw, pan (S/P washer) M4 × 16	0A5401-605	4
922	Washer, plain M4	025040-236	4
923	Nut, 1 M4	021400-106	4
924	EMI core, ESD - SR - 25	S40622-000	4
925	Band, PLTIM	S04557-000	2
926	Bead band, L	149809-000	1



Attachment set (Option parts)

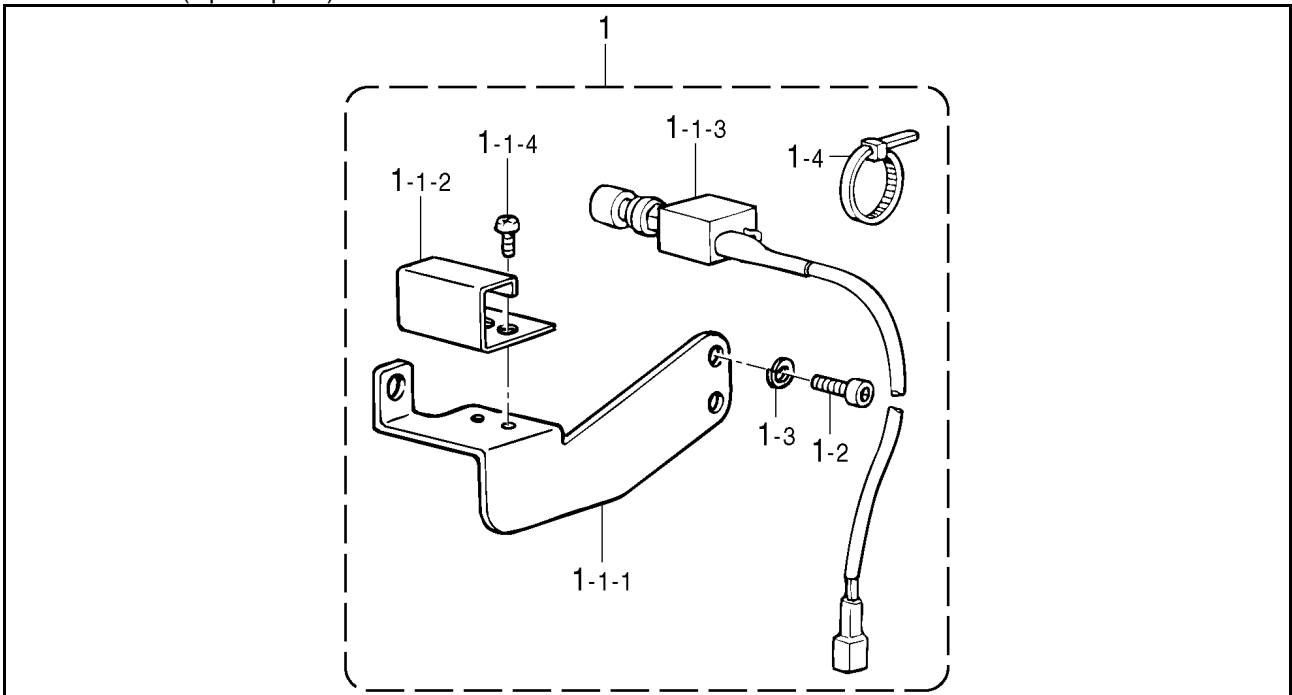

Ref. No.	Part name	Part code	Q'ty
1	Hand set switch device	S41639-001	1
1-1	Hand set switch assy	S41640-001	1
1-1-1	Hand switch base	S41638-001	1
1-1-2	Hand switch cover	S14972-001	1
1-1-3	Hand switch assy	S40496-000	1
1-1-4	Screw, truss M3×6	008300-604	2
1-2	Bolt, socket M4×6	018400-636	2
1-3	Washer, spring 2-4	028040-246	2
1-4	Band, PLTIM	S04557-000	3

Attachment set (Option parts)

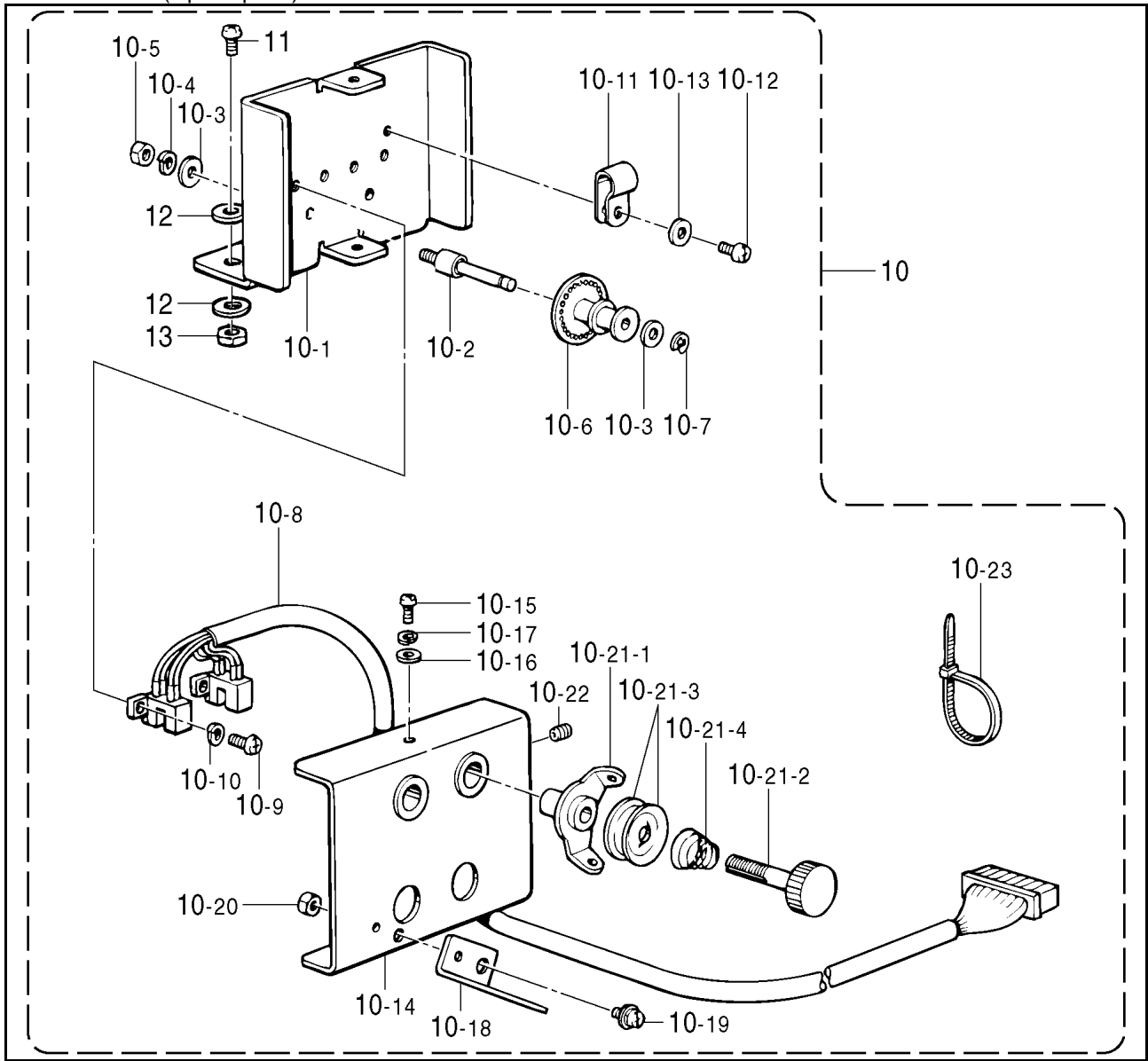

## Attachment set (Option parts)

Ref. No.	Part name	Part code	Qty
10	U-TR. breakage detector assy	S40520-009	1
10-1	Setting bracket	S09400-009	1
10-2	Fulcrum shaft	S09401-001	2
10-3	Washer, plain M3	025030-233	4
10-4	Washer, spring 2-3	028030-243	2
10-5	Nut, 1M3	021300-103	2
10-6	Pulley	S09402-101	2
10-7	Retaining ring, E2	048020-342	2
10-8	Thread breakage sensor assy	S40519-000	1
10-9	Screw, pan M3×6	062300-616	4
10-10	Washer, spring 2-3	028030-243	4
10-11	Cord holder, 5N	S00480-000	1
10-12	Screw, pan M4×6	062400-616	1
10-13	Washer, plain M4	025040-233	1
10-14	Cover	S09403-009	1
10-15	Screw, pan M3×6	062300-616	2
10-16	Washer, plain M3	025030-233	2
10-17	Washer, spring 2-3	028030-243	2
10-18	Face plate thread hook	S03566-001	1
10-19	Screw, pan (S/P washer) M4×8	052400-806	1
10-20	Nut, 2M4	021400-202	1
10-21	Pre-tension assy, A	183377-001	2
10-21-1	Thread guide	S02611-001	2
10-21-2	Pre-tension stud	S02612-001	2
10-21-3	Thread guide disc	144504-001	2
10-21-4	Spring, pre-tension (A)	154560-001	2
10-22	Set screw, socket (CP) M5	014500-522	2
10-23	Band, PLTIM	S04557-000	1
11	Screw, pan SM5.95- 28 × 12	062761-212	2
12	Washer, plain M6	025060-232	4
13	Nut, SM5.95	100022-005	2

Attachment set (Option parts)

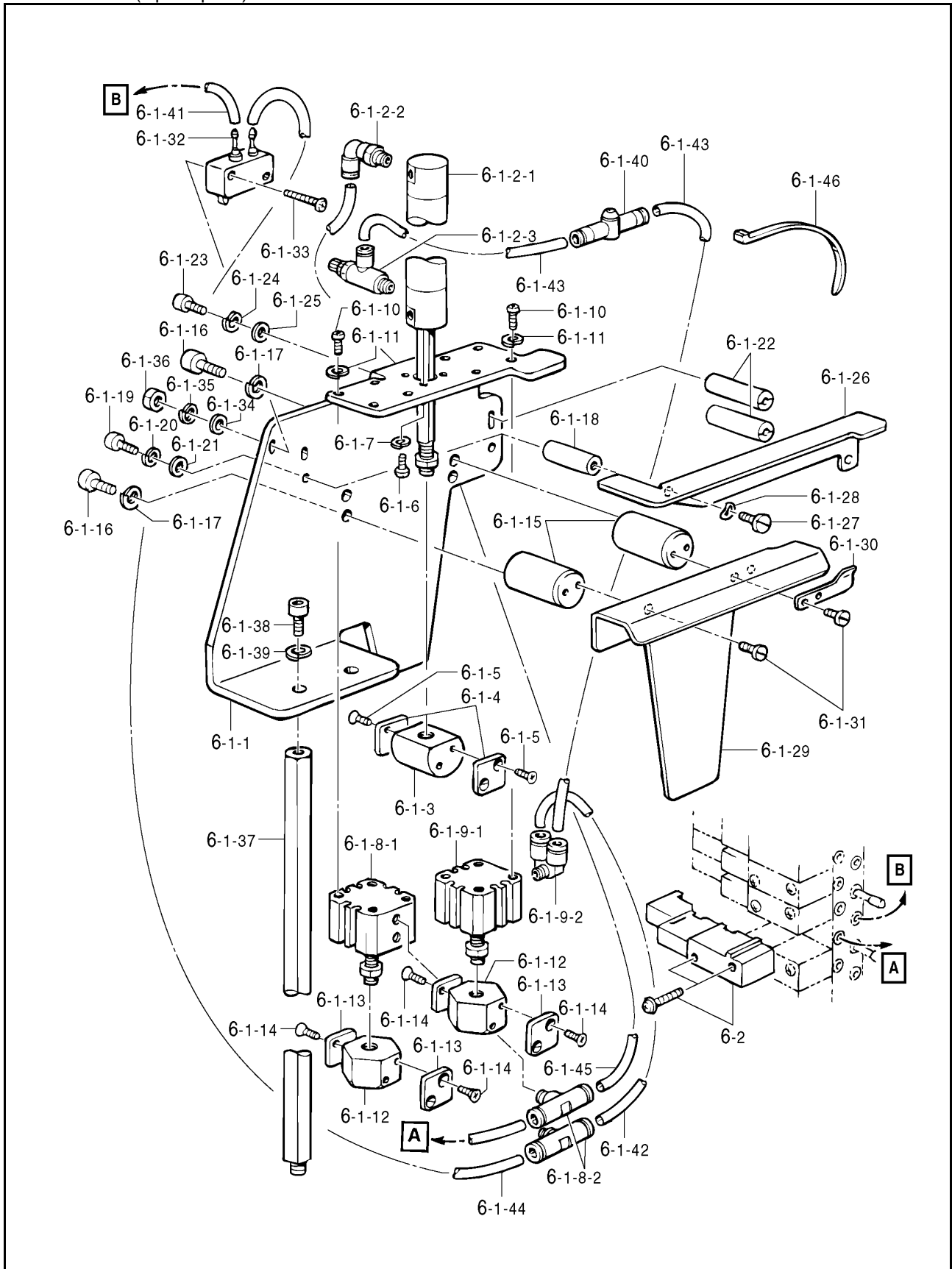

## Attachment set (Option parts)

Ref. No.	Part name	Part code	Q'ty
6	Belt feed device	S43632-000	1
6-1	Belt feed device, sub	S43622-001	1
6-1-1	Belt feed base	S43611-001	1
6-1-2	Cylinder assy, 20 - 125	S43623-000	1
6-1-2-1	Cylinder, 20 - 125	S43624-000	1
6-1-2-2	Elbow union	S04909-000	1
6-1-2-3	Speed controller	S23647-000	1
6-1-3	Belt guide	S43612-001	1
6-1-4	Spacer	S43613-000	2
6-1-5	Screw, flat M3×6	061300-616	4
6-1-6	Screw, pan M4×10	062401-016	4
6-1-7	Washer, spring 2-4	028040-246	4
6-1-8	Cylinder assy, 16 - 5	S43625-000	1
6-1-8-1	Cylinder, 16 - 5	S43627-000	1
6-1-8-2	T-joint, 4M5	S43628-000	2
6-1-9	Cylinder assy, 16 - 5	S43629-000	1
6-1-9-1	Cylinder, 16 - 5	S43630-000	1
6-1-9-2	Branch elbow, 4M5	S43631-000	1
6-1-10	Screw, pan M4×14	062401-416	8
6-1-11	Washer, spring 2 - 4	028040-246	8
6-1-12	Belt presser	S43614-001	2
6-1-13	Spacer	S43613-000	4
6-1-14	Screw, flat M3×6	061300-616	8
6-1-15	Guide shaft, B	S43615-001	2
6-1-16	Bolt, socket M5×12	018050-246	4
6-1-17	Washer, spring 2 - 5	028050-246	4
6-1-18	Guide shaft, A	S43616-001	1
6-1-19	Bolt, socket M4×12	018401-236	1
6-1-20	Washer, spring 2 - 4	028040-246	1
6-1-21	Washer, plain M4	025040-236	1
6-1-22	Guide shaft, C	S43617-001	2
6-1-23	Bolt, socket M4×12	018401-236	2
6-1-24	Washer, spring 2 - 4	028040-246	2
6-1-25	Washer, plain M4	025040-236	2
6-1-26	Guide cover	S43619-001	1
6-1-27	Shoulder screw, M4	S35221-001	1
6-1-28	Washer, wave spring 6.45	107017-002	1
6-1-29	Guide plate	S43618-001	1
6-1-30	Spring, plate	S43620-001	1
6-1-31	Screw, truss M4×6	008400-604	3
6-1-32	Micro valve, D	S01557-000	1
6-1-33	Screw, pan M3×20	062302-016	2
6-1-34	Washer, plain M3	025030-233	2
6-1-35	Washer, spring 2 - 3	028030-243	2
6-1-36	Nut, 1M3	021300-103	2
6-1-37	Post	S43621-001	2
6-1-38	Bolt, socket M6×12	018061-236	2
6-1-39	Washer, spring 2 - 6	028060-246	2
6-1-40	Quick exhaust	S37445-000	1
6-1-41	Air tube, L = 1400	S15031-006	2
6-1-42	Air tube, 4×145	S14085-005	1
6-1-43	Air tube, 4×73	S14085-012	2
6-1-44	Air tube, L = 120	S15031-001	1
6-1-45	Air tube, 4 (L = 260)	S18387-003	1
6-1-46	Band, PLTIM	S04557-000	2
6-2	Valve, VQZ1151 - 5	S39115-000	1

Attachment set (Option parts)

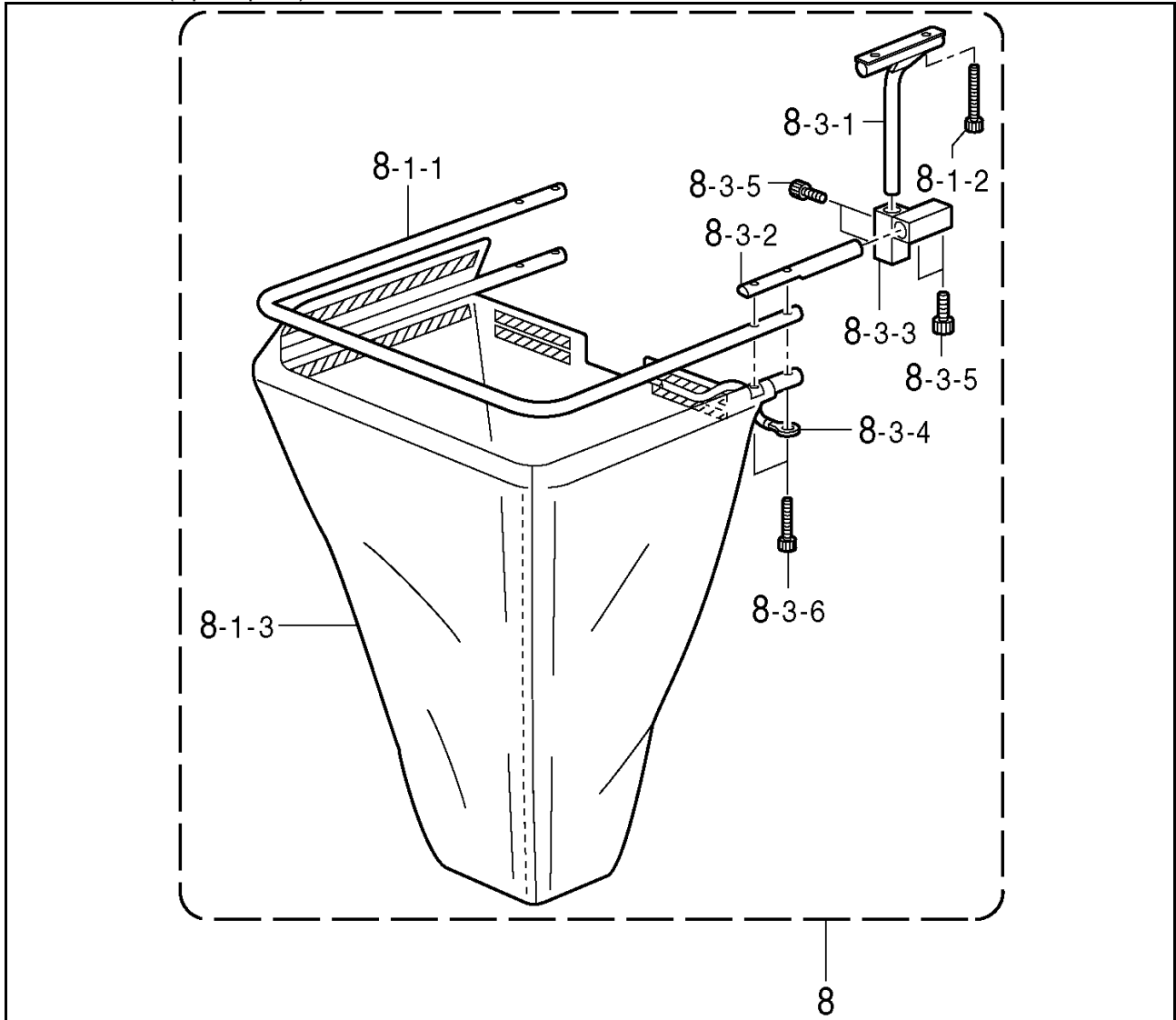

Ref. No.	Part name	Part code	Q'ty
8	Adjusting C-disposal device	S41776-001	1
8-1	Clipping disposal funnel assy	S41906-001	1
8-1-1	Cloth support bar	S41907-001	2
8-1-2	Bolt, socket M6×50	018065-002	4
8-1-3	Clipping disposal funnel	S41908-001	1
8-3	Adjusting device set	S41744-001	1
8-3-1	Vertical bar	S41732-009	2
8-3-2	Bar	S41739-001	2
8-3-3	Adjusting block	S41740-009	2
8-3-4	Cable	S41743-000	1
8-3-5	Bolt, socket M8×12	018081-236	8
8-3-6	Bolt, socket M6×30	018063-036	4